

Tuffline

FERTILIZER SPREADER OPERATOR'S MANUAL

MODEL SF300T



- Please read this manual carefully before operating the equipment

SF 300

TAB. A

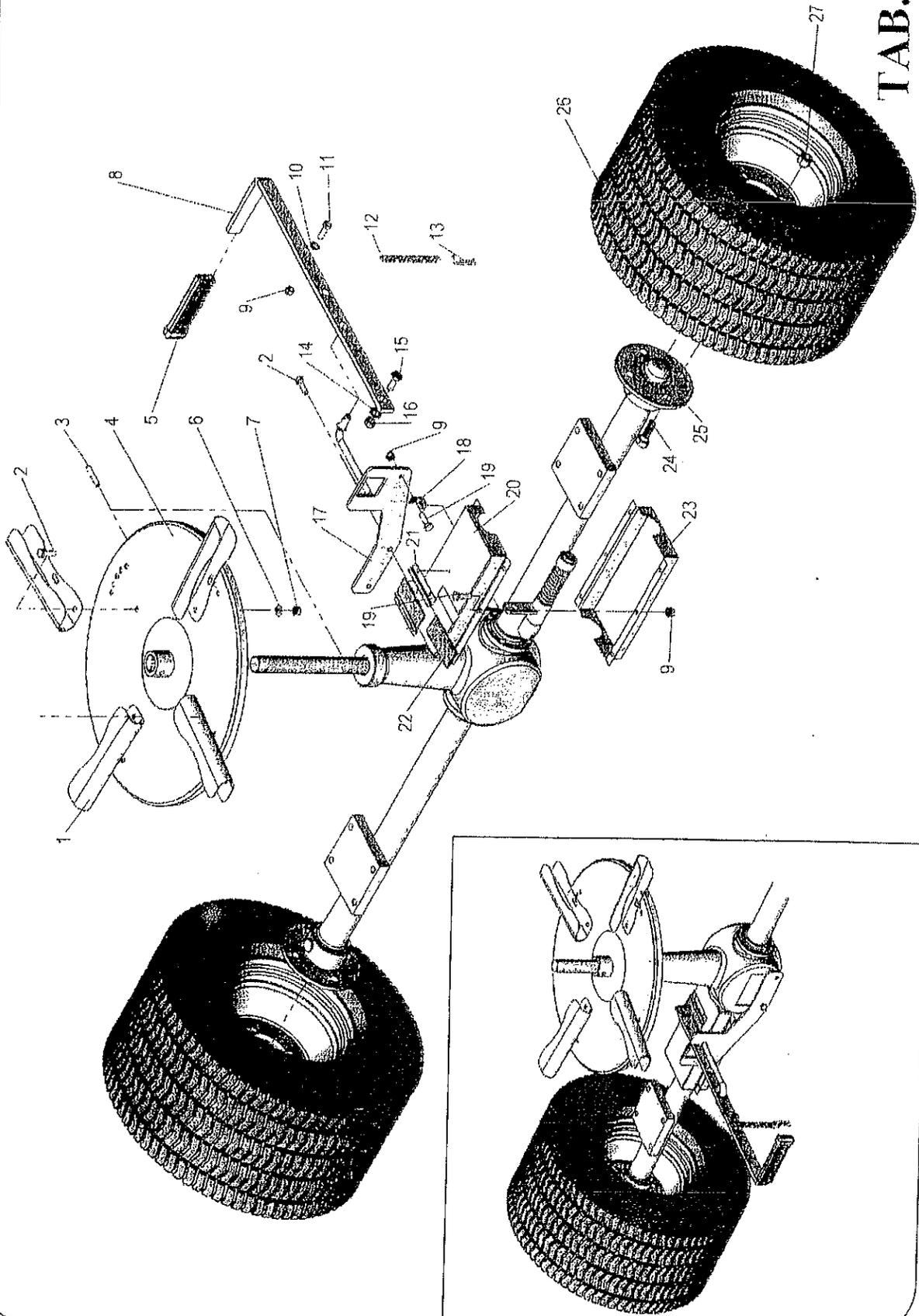

TUFline

FERTILIZER SPREADER SF300T

TABLE NR°	DESCRIPTION
A	Axle with disc

NO.	PARTS LIST	QTY	Part #
1	Vein	4	TUF01A
2	Galvanized Screw TE M8X20 ZN	10	TUF02A
3	Galvanized Pin 8x40 ZN	1	TUF03A
4	Vein Holder Disc	1	TUF04A
5	Handle Grip	1	TUF05A
6	Galvanized Washer M8 ZN	8	TUF06A
7	Self-Locking Nut M8	8	TUF07A
8	Disengagement Lever	1	TUF08A
9	Self-Locking Nut M6	8	TUF09A
10	Galvanized Washer M6 ZN	1	TUF010A
11	Galvanized Screw TE M6x25 ZN	1	TUF011A
12	Chain	1	TUF012A
13	Small 'R' Split Pin D.3	1	TUF013A
14	Galvanized Washer M10 ZN	1	TUF014A
15	Galvanized Screw TE M10x30 ZN	1	TUF015A
16	Self-Locking Nut M10	1	TUF016A
17	Gearbox Disengagement Lever Holder	1	TUF017A
18	Gearbox Box Holder	1	TUF018A
19	Galvanized Screw TE M6x15 ZN	7	TUF019A
20	Upper Punched Disengagement Housing	1	TUF020A
21	Brush Holder	2	TUF021A
22	Brush	2	TUF022A
23	Lower Disengagement Housing	1	TUF023A
24	Galvanized Screw TE M12x35 ZN	8	TUF024A
25	Axle	1	TUF025A
26	Wheel with Rim	2	TUF026A
27	Self-Locking Nut M12	8	TUF027A

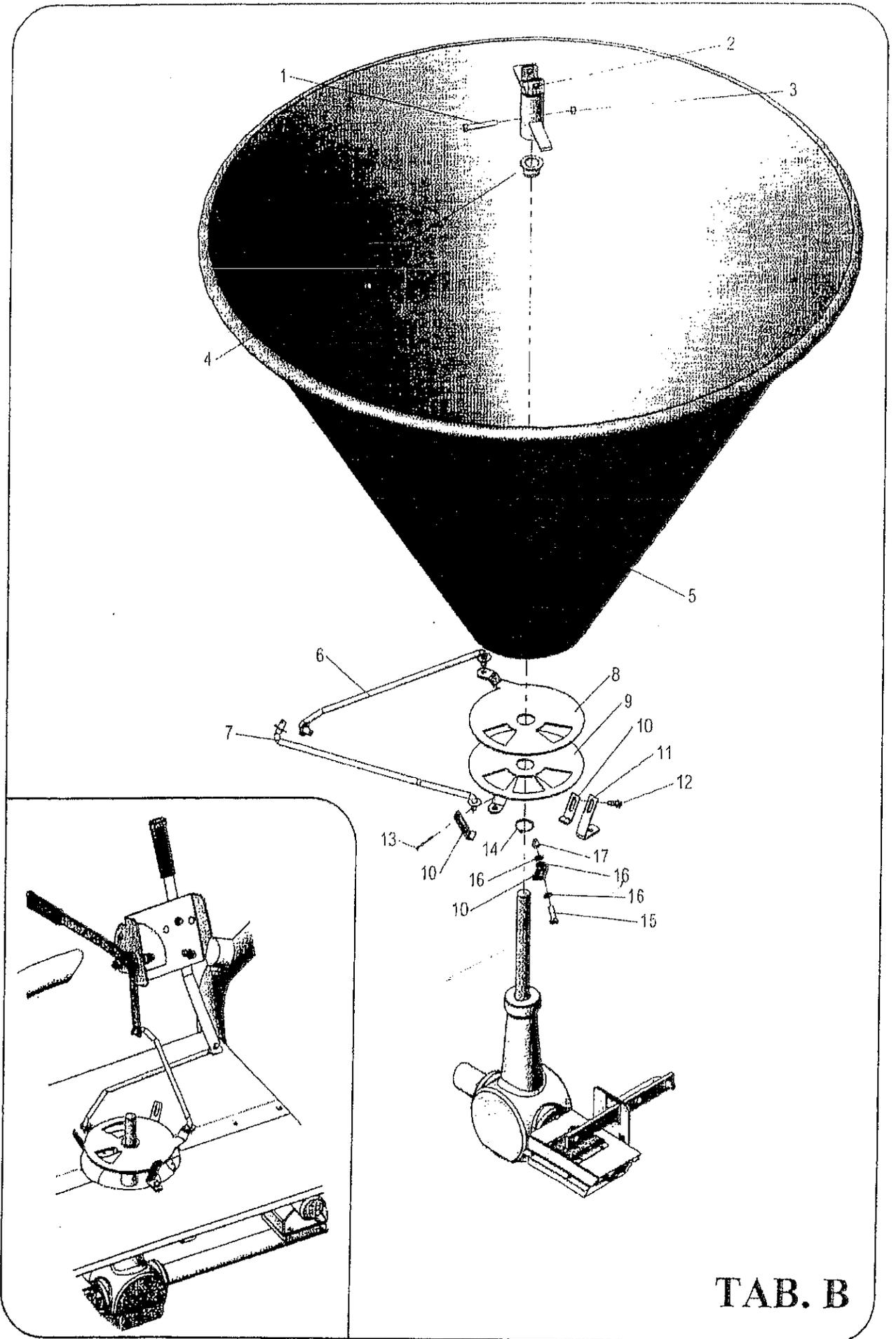

TAB. B

Tufline

FERTILIZER SPREADER SF300T

TABLE NR°	DESCRIPTION
B	Hopper with Discs

NO.	PARTS LIST	QTY	Part #
1	Galvanized Screw TE M8x55 ZN	1	TUF01B
2	Agitator	1	TUF02B
3	Self-Locking Nut M8	1	TUF07A
4	Agitator Bushing	1	TUF04B
5	Hopper	1	TUF05B
6	L.H. Connecting Rod	1	TUF06B
7	R.H. Connecting Rod	1	TUF07B
8	Upper Opening Ring	1	TUF08B
9	Lower Opening Ring	1	TUF09B
10	Ring Holder	3	TUF010B
11	Carter Holder	1	TUF011B
12	Galvanized Screw TE 8x25 ZN	1	TUF012B
13	Split Pin 3x20	4	TUF013B
14	Snap Ring	1	TUF014B
15	Galvanized Screw TE 8x20 ZN	2	TUF02A
16	Galvanized Washer M8 ZN	9	TUF06A
17	Galvanized Nut M8 ZN	3	TUF017B

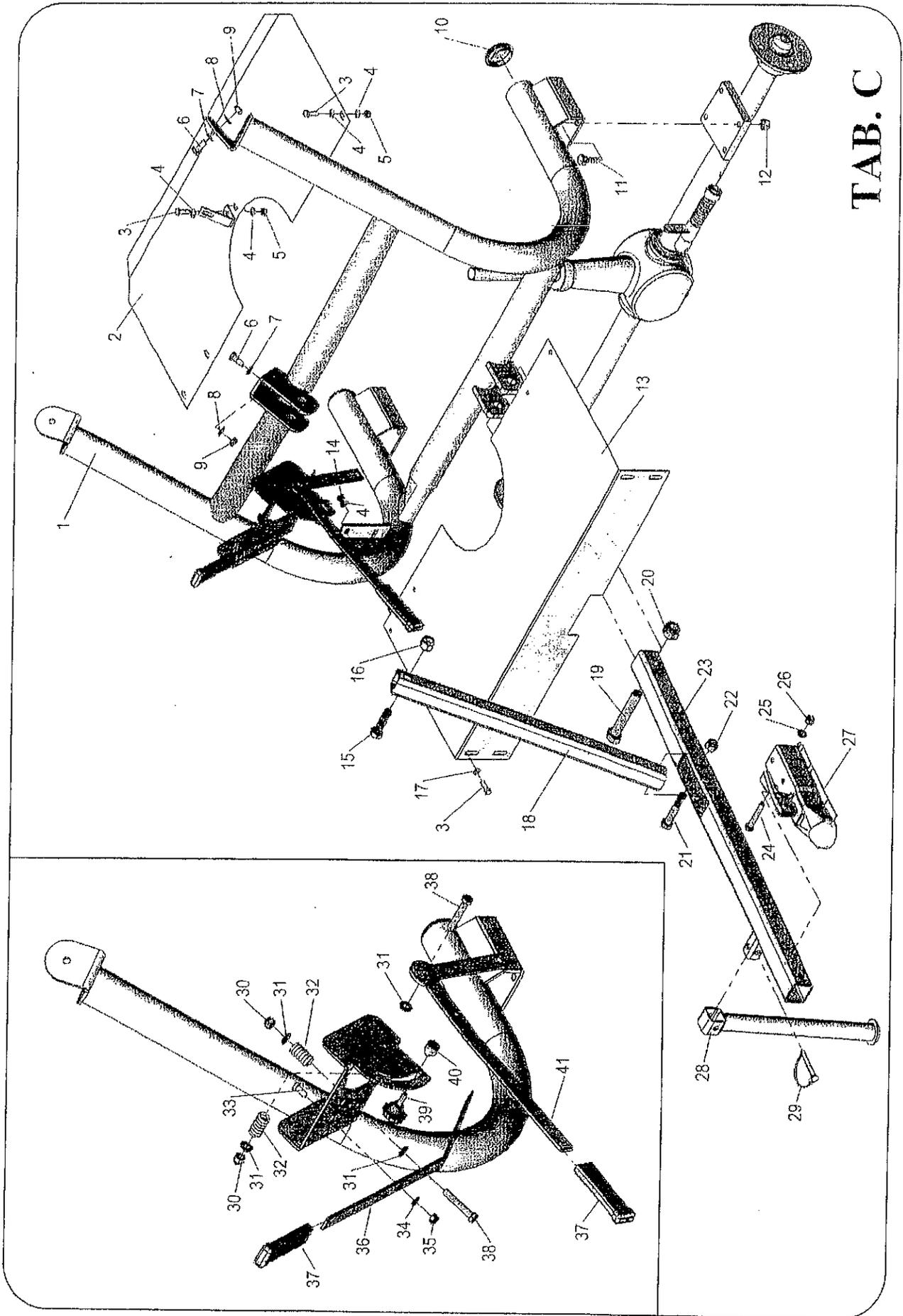

TAB. C



FERTILIZER SPREADER SF300T

TABLE NR°	DESCRIPTION
C	FRAME WITH BEAM

NO.	PARTS LIST	QTY	Part #
1	Frame	1	TUF01C
2	Rear Guard	1	TUF02C
3	Galvanized Screw TE M8x20 ZN	9	TUF02A
4	Galvanized Washer M8 ZN	14	TUF06A
5	Self-Locking Nut M8	5	TUF07A
6	Galvanized Screw TE M10x25 ZN	3	TUF06C
7	Galvanized Washer M10 ZN	3	TUF014A
8	Galvanized Washer M10 ZN	3	TUF014A
9	Nut M10	3	TUF09C
10	Rubber Cap	2	TUF010C
11	Galvanized Screw TE M10x25 ZN	8	TUF06C
12	Self-Locking Nut M10	8	TUF016A
13	Front Guard	1	TUF013C
14	Galvanized Nut M8 ZN	4	TUF017A
15	Galvanized Screw TE M18x80 ZN	1	TUF015C
16	Self-Locking Nut M18	1	TUF016C
17	Galvanized Washer M8 ZN	4	TUF06A
18	Height Adjustment Rod	1	TUF018C
19	Galvanized Screw TE M20x100 ZN	1	TUF019C
20	Self-Locking Nut M20	1	TUF020C
21	Galvanized Screw TE M14x70 ZN	1	TUF021C
22	Self-Locking Nut M14	1	TUF022C
23	Tongue	1	TUF023C
24	Galvanized Screw TE M10x70 ZN	2	TUF024C
25	Galvanized Washer M10 ZN	2	TUF014A
26	Self-Locking Nut M10	2	TUF016A
27	1-7/8" Ball Hitch	1	15008
28	Standing	1	TUF028C
29	Pin 0 10	1	TUF029C
30	Self-Locking Nut M10	2	TUF016A
31	Galvanized Washer M10 ZN	4	TUF014A
32	Small Spring	2	TUF032C
33	Galvanized Hexagonal Screw 8x20 ZN	1	TUF033C
34	Galvanized Washer M8 ZN	1	TUF06A
35	Self-Locking Nut M8	1	TUF07A
36	L.H. Lever	1	TUF036C
37	Handle Grip	2	TUF05A
38	Galvanized Screw TE M10x60 ZN	2	TUF038C
39	Pommel M8x15	1	TUF039C
40	Lever Stop	1	TUF040C
41	R.H. Lever	1	TUF041C

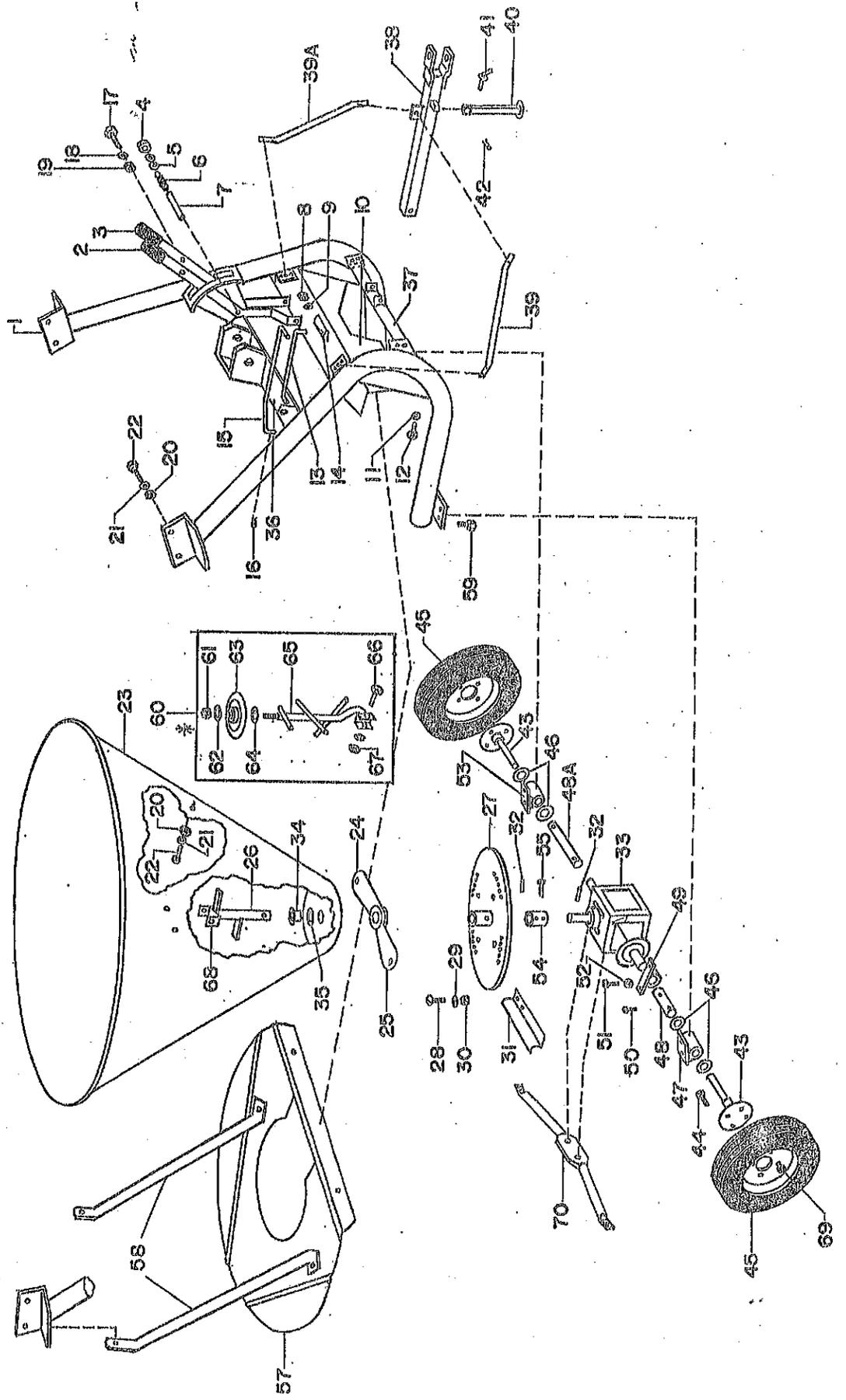

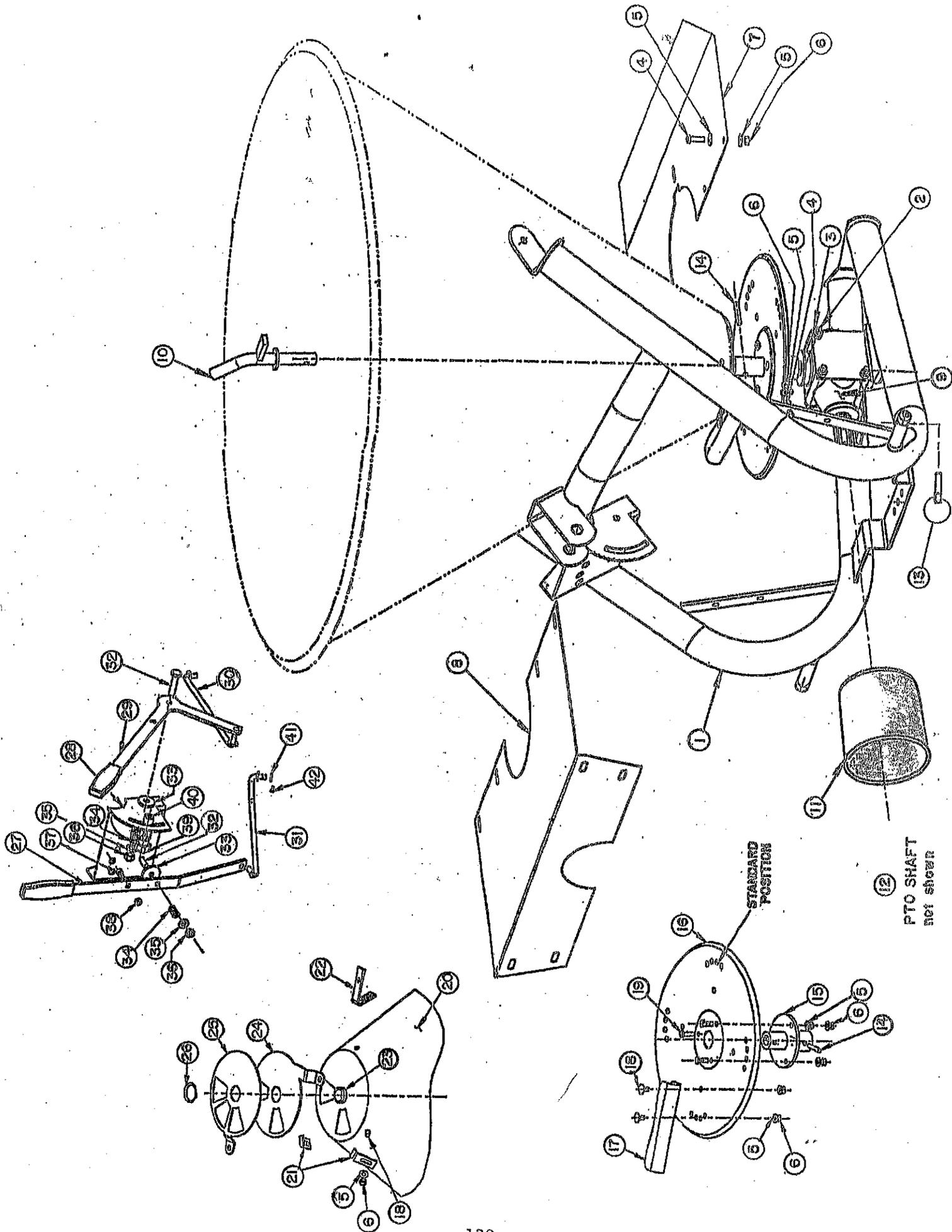

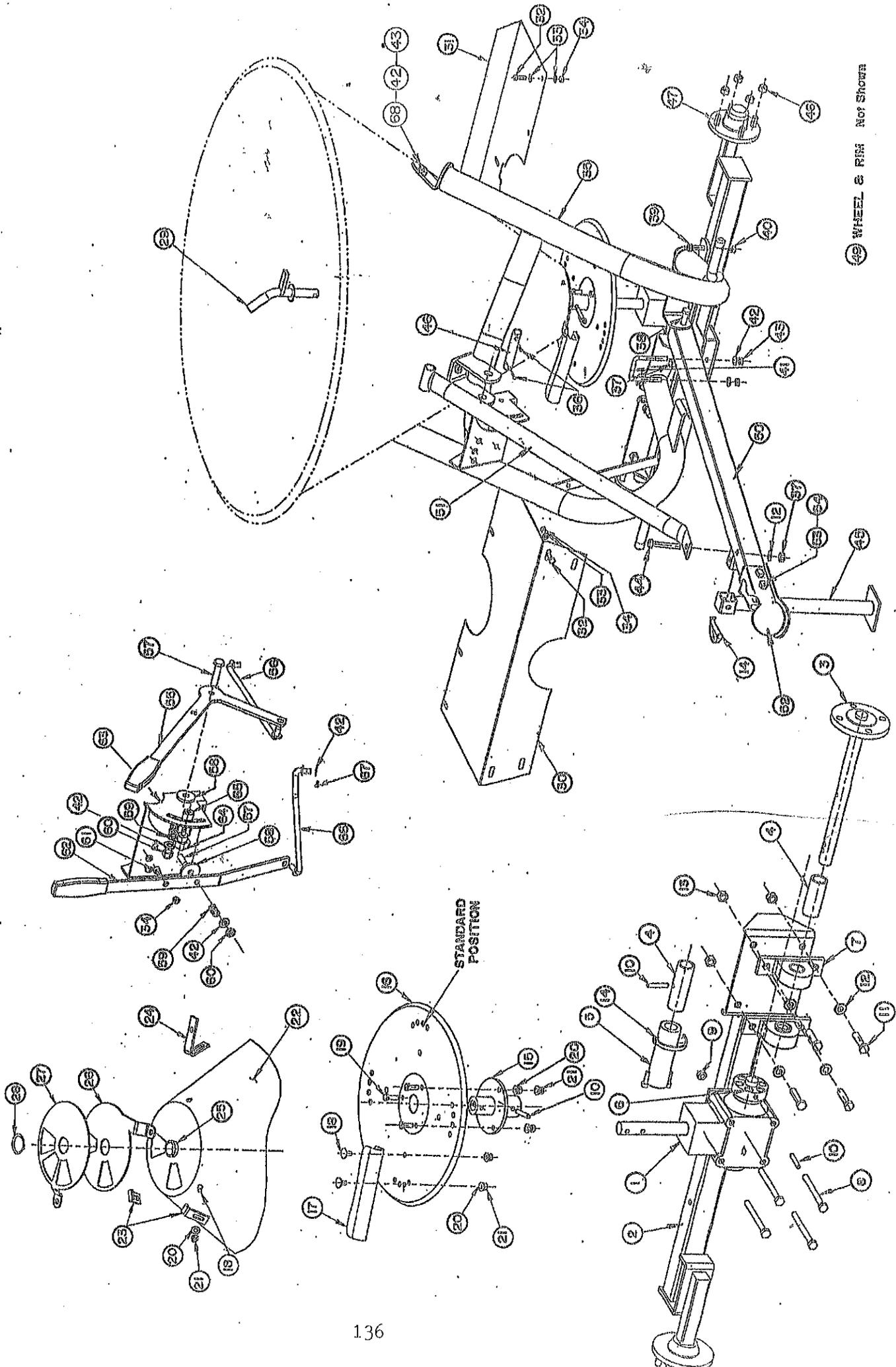

49 WHEEL & RIM NOT SHOWN

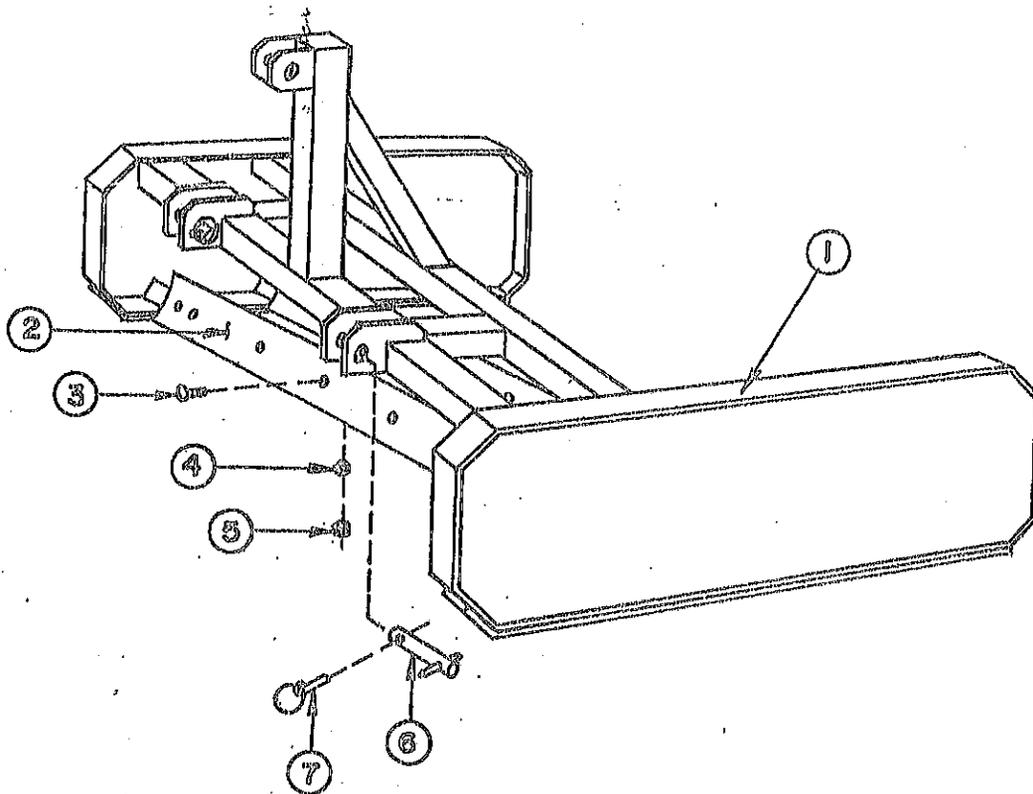

LAND PLANE

REF. NO.	PART #	DESCRIPTION
1	14789	MAIN FRAME WELDMENT 60"
	14790	MAIN FRAME WELDMENT 72"
	14791	MAIN FRAME WELDMENT 84"
	14792	MAIN FRAME WELDMENT 96"
2	10702	CUTTING EDGE, 60"
	10704	CUTTING EDGE, 72"
	10705	CUTTING EDGE, 84"
	10706	CUTTING EDGE, 96"
3	10699	PLOW BOLT, 5/8" X 1 1/2", GR. 5
4	T-24	LOCK WASHER, 5/8
5	T-22	HEX NUT, 5/8"
6	10684	HITCH PIN, 7/8" CAT. 1
7	VP252	LYNCH PIN

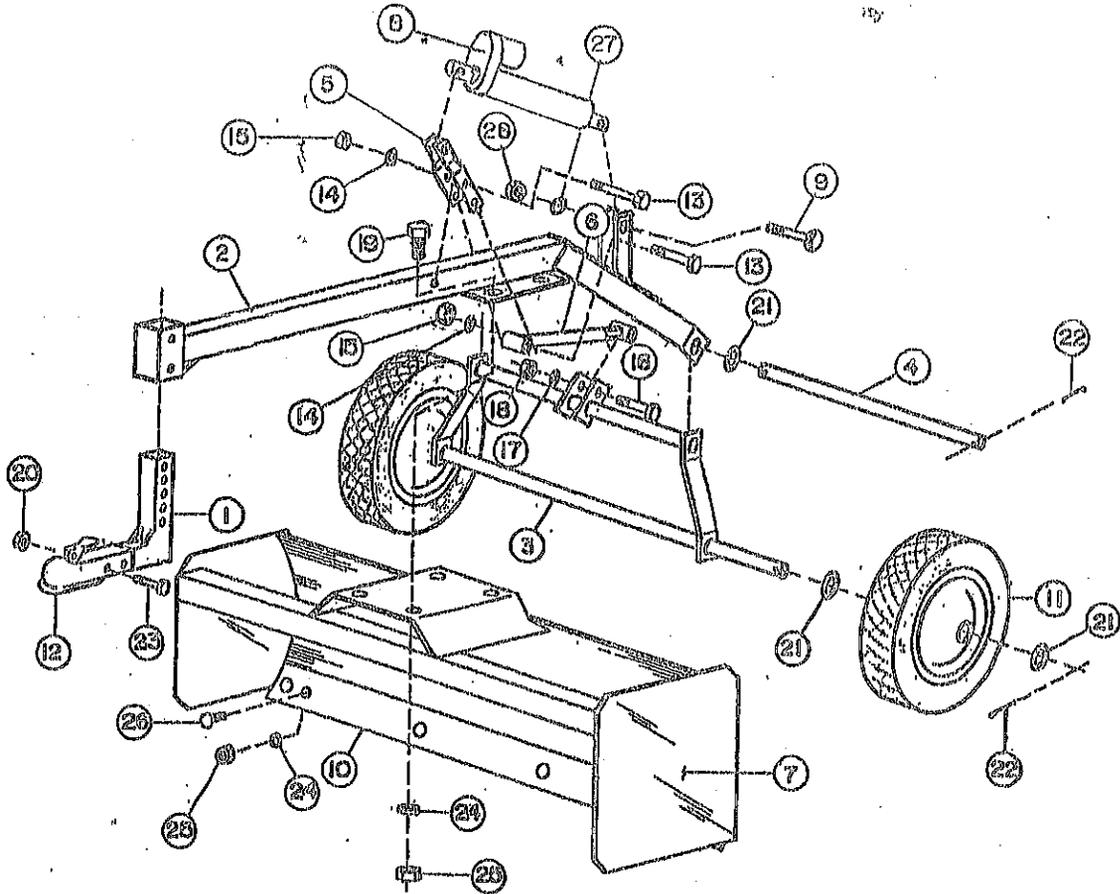

ATVB-H

REF. NO.	PART #	DESCRIPTION
1	15004	HITCH ADJUSTMENT WELDMENT, (ATVB-H)
2	14837	MAIN FRAME WELDMENT, (ATVB-H)
3	15105	WHEEL CARRIAGE WELDMENT
4	15109	WHEEL CARRIAGE AXLE
5	14839	LIFT ADJUSTMENT LEVER
6	15152	WHEEL CARRIAGE ADJUSTMENT ARM WELDMENT
7	15142	MOLDBOARD AND BOX WELDMENT, 42"
	15143	MOLDBOARD AND BOX WELDMENT, 48"
8	14822	LINEAR ACTUATOR
9	14840	HEX BOLT 1/2" X 3" GR. 5
10	15154	CUTTING EDGE, 42"
	15155	CUTTING EDGE, 48"
11	15156	WHEEL & TIRE ASSEMBLY, 12"
12	15008	BALL COUPLER, 1 7/8"
13	15129	HEX BOLT 3/8" X 3 1/2" HEX BOLT GR. 5
14	15130	FLAT WASHER, 3/8"
15	15131	HEX LOCK NUT, 3/8" WITH NYLON INSERT
16	T-742	HEX BOLT 3/8" X 3 1/2" GR. 5
17	9354	FLAT WASHER, 5/8"
18	15132	HEX LOCK NUT, 5/8" WITH NYLON INSERT
19	T-740	HEX BOLT, 5/8" X 2", GR.2
20	12899	FLANGE NUT, 3/8"
21	9354	FLATWASHER, 5/8" (if necessary)
22	15134	COTTER PIN, 5/32" X 2"
23	12165	HEX BOLT, 3/8" X 3" GR. 2
24	T-24	LOCKWASHER, 5/8"
25	T-22	HEX NUT, 5/8"
26	10699	PLOW BOLT, 5/8" X 1 1/2"
N/S	15157	WHEEL BEARING, 5/8" (not shown, mounts in part# 15156)
27	T-25	LOCKWASHER 1/2"
28	T-26	HEX NUT 1/2"

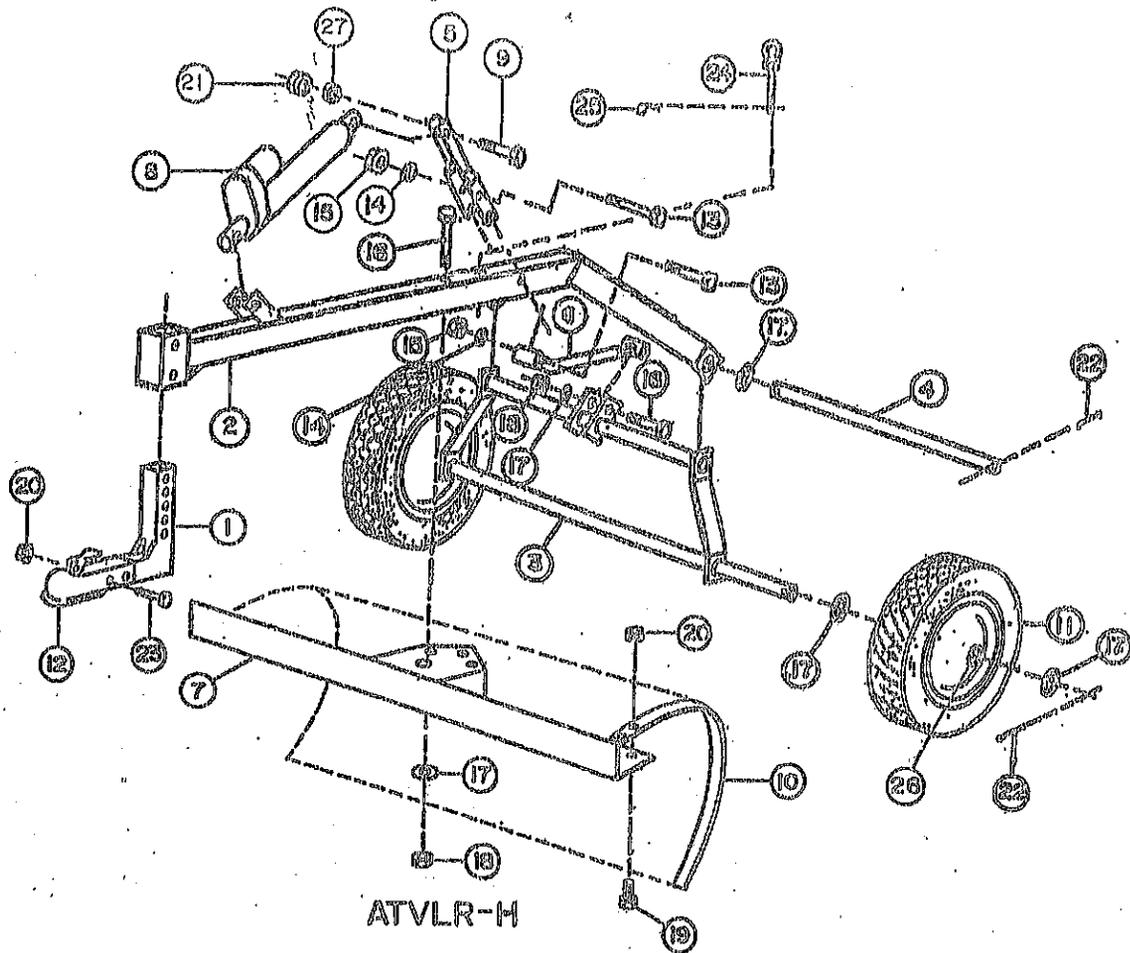

REF. NO.	PART #	DESCRIPTION
1	15004	HITCH ADJUSTMENT WELDMENT, (ATVLR)
2	14841	MAIN FRAME WELDMENT, (ATVLR-H)
3	15159	WHEEL CARRIAGE WELDMENT
4	15121	PIVOT PIN (WHEEL CARRIAGE)
5	14843	ACTUATOR LEVER
6	15114	WHEEL CARRIAGE ADJUSTMENT ARM WELDMENT
7	15122	TOOL BAR WELDMENT, 48"
	15123	TOOL BAR WELDMENT, 60"
8	14622	LINEAR ACTUATOR
9	14840	HEX BOLT 1/2" X 3" Gr.5
10	14149	RAKE TOOTH
11	15099	WHEEL & TIRE ASSEMBLY, (INCLUDES BEARING)
12	15008	BALL COUPLER, 1 7/8"
13	15129	HEX BOLT 3/8" X 3 1/2" HEX BOLT GR. 5
14	15130	FLAT WASHER, 3/8"
15	15131	HEX LOCK NUT, 3/8" WITH NYLON INSERT
16	T-742	HEX BOLT 5/8" X 3 1/2" GR. 5
17	9354	FLAT WASHER, 5/8"
18	15132	HEX LOCK NUT, 5/8" WITH NYLON INSERT
19	14150	HEX BOLT, 3/8" X 1 1/2"
20	12899	FLANGE NUT, 3/8"
21	T-26	HEX NUT 1/2"
22	15134	COTTER PIN, 5/32" X 2"
23	12165	HEX BOLT, 3/8" X 3" GR. 2
24	15135	PULL PIN
25	15136	HAIR PIN
26	15157	WHEEL BEARING 5/8" (mounts in part#15099)
27	T-27	LOCKWASHER 1/2"

